

Beyond  
any  
measure



Optimet Industrial  
Catalog 2017

# Who are we?

Optimet (Optical Metrology) product line was founded in 1995 by Ophir Optronics Solutions. Ophir Optronics, now a part of MKS Instruments, is a global leader in precision IR optics, laser measurement instrumentation and 3D non-contact measurement equipment. Optimet develops and manufactures non-contact distance measurement sensors based on the patented Conoscopic Holography technology.

## Introduction to Conoscopic Holography

Conoscopic Holography measures distances by using the polarization properties of a converging light cone that reflects from an object. At the core of the technology stands an anisotropic crystal: the ray traversing the crystal splits into two components which share the same path but have orthogonal polarizations. The crystal's anisotropic structure forces each of the polarized light rays to propagate at a different velocity, thus creating a phase difference between them. This phase difference enables the formation of an interference pattern which varies with the distance from the object under measurement.

# How does the sensor work?

The sensor emits laser beam which is projected onto the measured object. All of the reflected rays that are collected by the objective lens enter the conoscopic module. The resulting interference pattern is analyzed to determine the distance to the object.

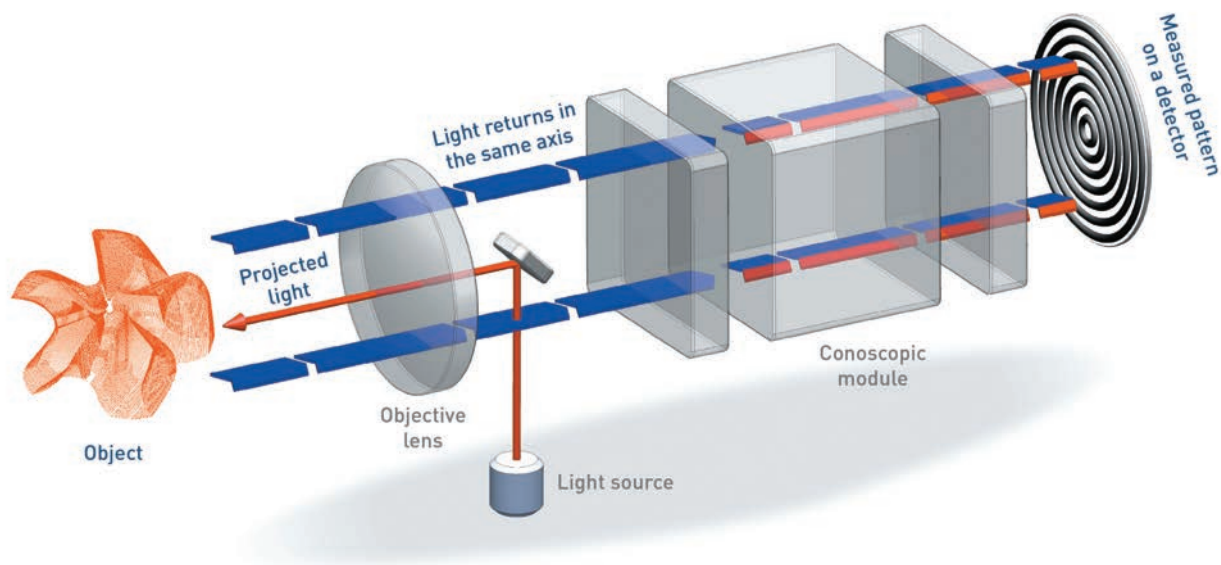

# Our advantages

Optimet's sensors are based on the unique and patented Conoscopic Holography technology, which is advantageous over standard distance measurement methods used for various industrial applications. The sensors are reliable, accurate and contain no moving parts. Our technology has major benefits when integrated in measurement systems compared to the standard triangulation method. Two major advantages are:

- **Collinearity:** our sensor's outgoing laser beam share the same optical axis as the reflected signal. This collinearity allows the sensor to measure inside holes, through folding optics, and steeply-inclined surfaces of up to  $\pm 85^\circ$ . The ability to incorporate relay optics enables the sensor to be used simultaneously with the same focusing lens of laser welding or cutting applications and with machine vision applications.
- **Low electronic noise dependency:** in Optimet's sensors the entire detector is used to evaluate a single spatial frequency, making the measurement highly noise resilient. Moreover, if some of the light is blocked, other areas can provide sufficient measurement signal.

Here are some of the unique properties of our sensors:

## Universality and cost-efficiency

Optimet's sensors are able to measure objects ranging from sub-microns to half a meter, using interchangeable lenses.



## Versatility and robustness

Optimet's sensors can measure different types of surfaces, such as reflective, translucent, and diffusive, with no need for coating measurement-enhancing materials.



## Complex feature measurement

The sensor's collinear operation allows measurement of deep and narrow slots, grooves and holes.



## Grazing incidence measurement

Optimet's sensors are capable of measuring angles very close to normal incidence, as high as  $85^\circ$ . This unique capability permits the reproduction of complex shapes with high fidelity to the original model without distorting the profile.



# Applications

There is a growing need for improved measurement solutions which offer higher precision, speed and accuracy that will provide better in-process inspection measurements, resulting in lower manufacturing costs and improved products. Optimet's innovative sensors overcome the limitations of many existing measurement devices, in many cases providing the only comprehensive solution for complex measurement problems. Optimet has a great variety of sensor configurations which address a large number of demands of metrological measurements associated with many kinds of material surfaces. For choosing the right sensor configuration the user must identify what kind of material is involved, along with its surface properties. More specifically, is the material diffusive or reflective? Transparent or translucent? Each material has its own physical and optical properties that must be taken into consideration. Other factors which need to be taken into account are the standoff from the object, the measurement range of the sensor and of course the precision needed for the specific application.

A major advantage of Optimet's sensors is the separation between the sensor and the lens. Each sensor head can be used with a large variety of lenses. This advantage allows a single sensor to cover a large measuring range, standoff (distance from sensor to the center of measurement range) and accuracy. Furthermore, Optimet's technology has real time control and filtering of SNR (Signal to Noise Ratio) and Total (relative laser power collected) of the signal retrieved. These unique technological properties along with the collinear optical configuration allow the perfect setup to match most known applications.

Here are a few examples representing a large variety of applications which we've put into practice:

## A. Autofocus for Laser Marking, Welding, Drilling and Cutting Systems Using Optimet's Non-Contact Distance Sensors

Conventional laser marking, welding, drilling and cutting systems often struggle with focusing the laser precisely on the object's surface. Optimet sensors offer a unique solution for autofocusing laser systems. Integrating Optimet's non-contact distance measurement sensors into laser systems improves the autofocus functionality, facilitates the laser system setup, and simplifies measuring when there is no CAD available. Optimet sensors measure distance using a unique co-linear Conoscopic Holography technology and can be applied in the laser system's optical path. In addition, since the sensor's illumination design is collimated, the lens can be far from the sensor because measurement is performed through the objective lens of the laser system itself! Some of our customers have successfully integrated the sensor as far as two meters from the laser's objective lens.

**Keep in focus:** Continuous distance data at high rate allows the system be in focus regardless of the surface shape.

**Faster:** High measurement rate enables laser systems to run faster than in any other system configuration.

**Accurate:** Using the adjustable focus in real time provides accurate color shade in laser marking systems.

**Adjustable:** Optimet sensors automatically adjusts the sensor's exposure when moving from black surfaces with low reflectivity (0.3%) to white surfaces with high reflectivity (99%).

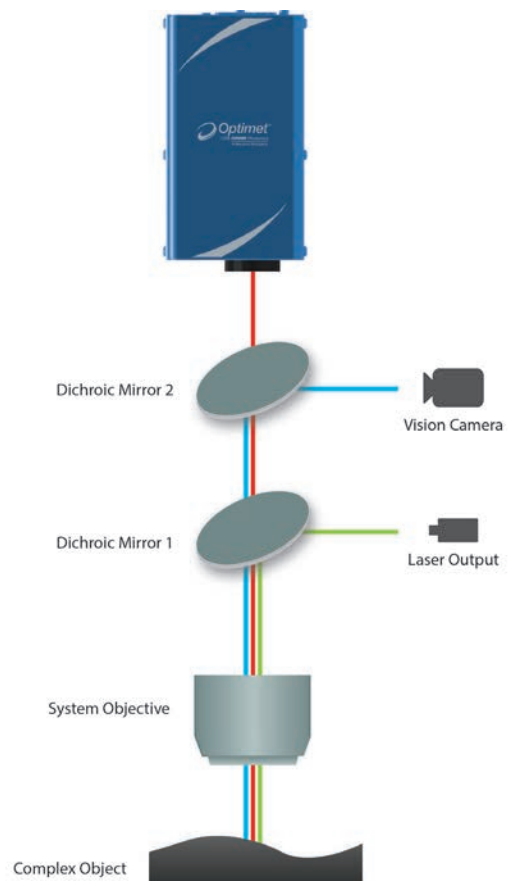

## B. Laser engraving measurement

### Measurement of Laser Engraved Objects

Engravers use a hardened steel tool to engrave the design into the surface. Using Optimet's non-contact distance sensor allows the user to accurately measure the depth of the engraved area. Due to its wide angle coverage the Optimet sensors is capable of measuring engraved objects that other sensors cannot.

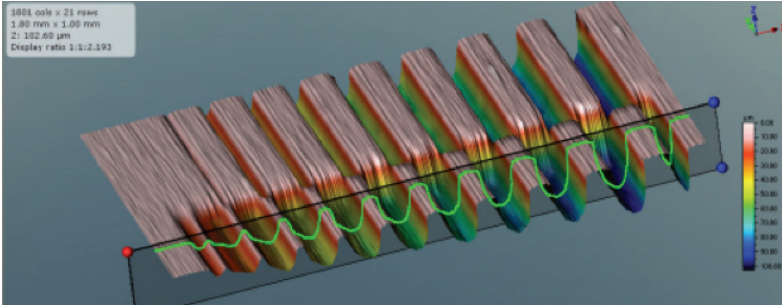

## C. Glass screen scratch inspection

In a world dominated by cellphones and display screens, the inspection of scratches is crucial for yield and profit. Scratch properties such as depth and width determine if the screen can be refurbished according to predetermined criteria.

Using Optimet's ConoPoint-3R or Mini ConoPoint-9R with 25mm focal length lens the scratches on the screen's top surface are scanned and analyzed. Optimet is very familiar with this type of market application and it is already being used as part of the inspection process for manufacturers of phone products in China and Korea.

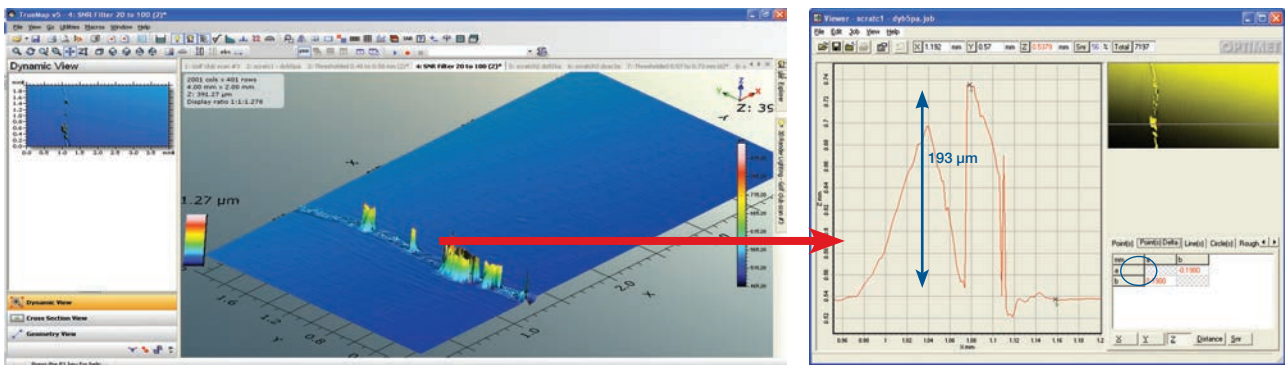

## D. Tire mold inspection

In the application of rubber manufacturing, and especially with tires, the inspection and quality control of molds and mold segments is most important. This might be a challenging field since it demands high precision along with long standoff and large measurement range. The retrieved data during inspection includes, among others, the segment's height, width, angle and roughness. Optimet's ConoPoint-10 with 50mm lens is able to determine all these parameters with just a single scan and can compare it to the original drawing for quality assurance purpose using a CAD-CAM or a CAD-compare software.

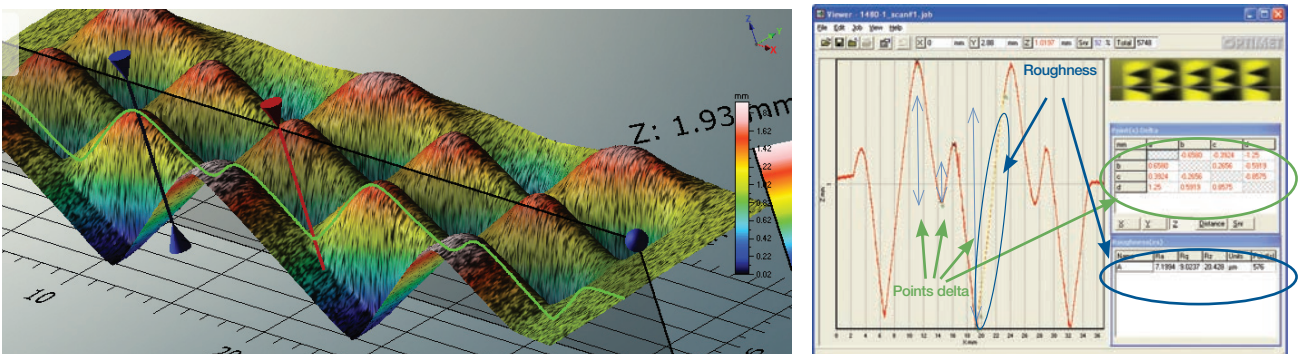

## E. CAD compare

Comparing CAD models of free form bodies to the actual dimensions, measured by a high precision sensor, can turn out to be a very complex task. The comparison is usually addressed in the areas of R&D, manufacturing and QC processes in various industrial applications such as casting, forging, welding and metal sheet forming. The CAD compare process is used in a wide range of industries from turbine blades and aerospace components to automotive engine body structure and transmission parts. The capability of comparing is particularly very important in the mold-manufacturing field since the quality and accuracy of the products are based on the accuracy of the original mold. By scanning the mold and comparing it to its original CAD one can be sure that the mold was manufactured according to specifications. CAD compare is possible by using a number of standard software packages.

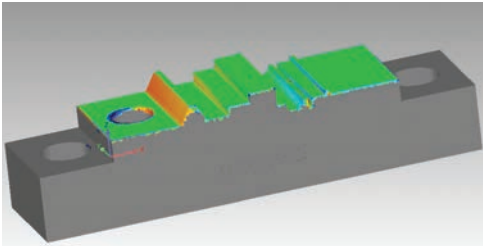

Metrological model showing the difference between nominal and actual values on a color scale.

## F. Hole measurement – depth, diameter and angles

Optimet's technology allows integration of a periscope to the sensor's head. Using collinearity, one of Optimet's major advantages, enables scanning inside deep holes or enclosures to obtain the internal depth, diameter and angle. This special property is used in measuring engine holes and various types of pipes where the inner structure is important.

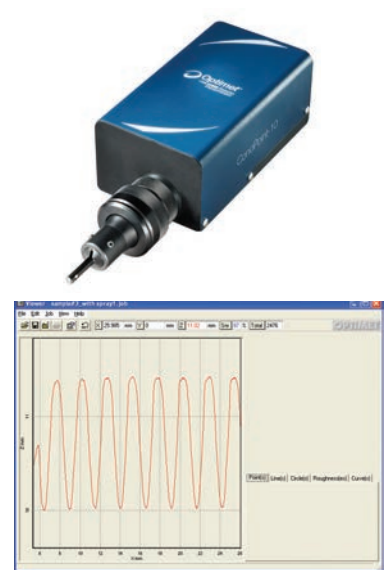
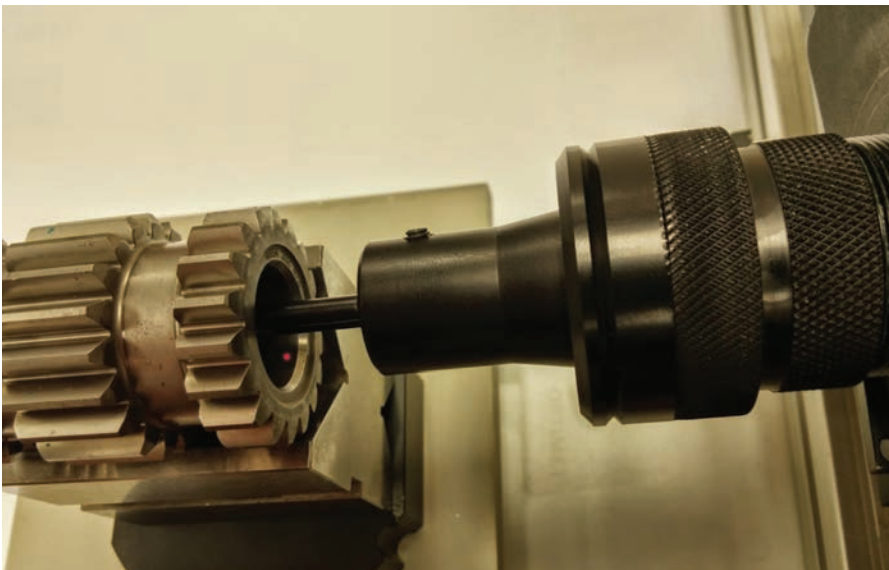

## G. Tire inspection

There is a major industrial need for a non-contact remote sensing device for tire tread inspection. This task is accomplished by continuously scanning the tire surface using a laser point sensor. The tire is rotated and the beam position is incremented by a fraction once per revolution parallel to the spinning axis.

There are two types of requirements for evaluating tire surface:

- Quality inspection: groove and sipe depths are measured as part of the QC process to ensure the tire was manufactured according to its design specifications.
- Performance inspection: tire wear rates are analyzed in order to ascertain the tire degradation as a function of traveled distance in various working environments.

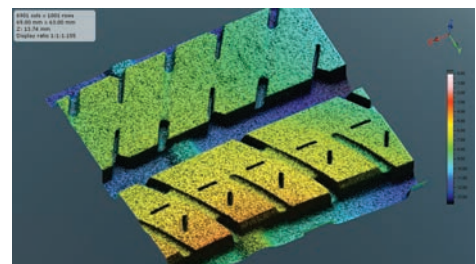

Tire sipes, characterized by narrow deep channels, and tire grooves, characterized by wide and deep features, have both steep angles (usually above 75°).

To obtain a precise measurement of the angles, a collinear measurement is required. Thus, ensuring that the signal originating from the groove or sipe base is not disturbed by the side walls. Using Optimet's sensor, provides the solution.

Auto-exposure is a unique feature in Optimet's sensors and can be used when measuring highly variable reflective surfaces as shown below. Pink signal (left) indicates insufficient data.

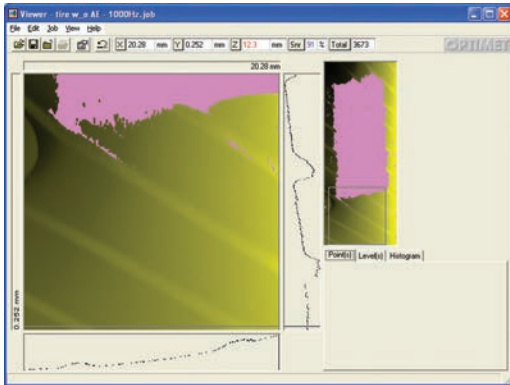

Scan without auto-exposure



Image of tire with white paint

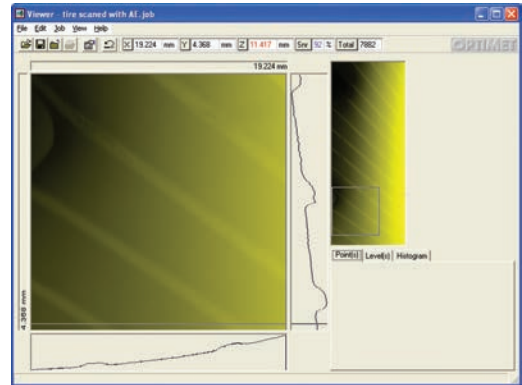

Scan with auto-exposure

# ConoPoint-10 **NEW** SMART Sensor

## Laser displacement sensor with SMART technology inside

The ConoPoint-10 Smart sensor is the first sensor in a new family of Optimet's Non-Contact Laser Displacement Sensors. The new Smart technology contains a rich set of algorithms which makes integration easy and provides pass/fail results rather than a simple displacement value.

The ConoPoint-10 Smart sensor measures 10,000 points/sec and retains all of Optimet advantages. This new sensor allows fast 2D profile measurement, analysis and feature evaluation. The built in Smart technology also provide a standalone sensor using Web based interface without the need of installing software on customer host.

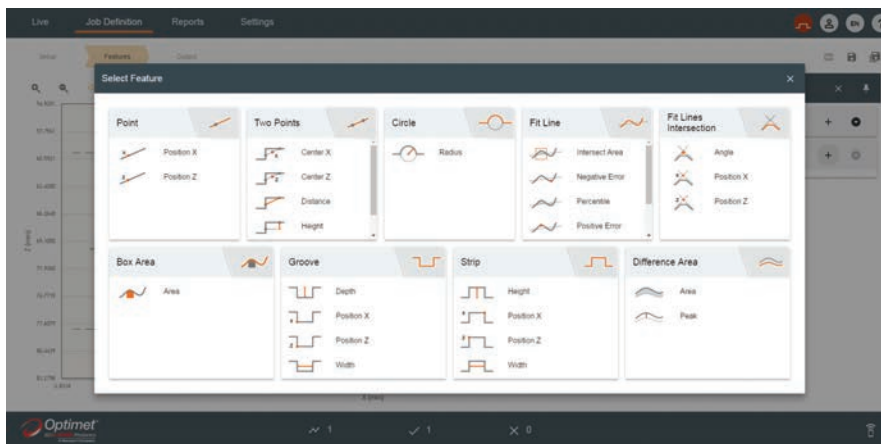

## Features:

- Measurement of Complex Geometries & Steep angles with up to +/-85° angular coverage
- Profile analysis using built-in feature library such as: distance, height, angle, radius, and many more
- Go/NoGO output results
- Web based, no software installation required
- External triggers, digital input & digital output
- Built-in filters for smooth point array
- Configurable encoder input and pulse to position conversion
- Collinear technology for measuring inside holes
- Automatically compensates for material variations using auto-exposure
- Interchangeable objective lenses from 16 to 250 mm
- Measures up to 10000 points/second



# Technical specification

## Standard lenses

Objective lens type		16	25	25G	40	50	75	100	150	200	250
P/N		3Z83016	3Z83025	3Z81030	3Z83040	3Z81050	3Z81075	3Z81100	3Z82006	3Z82007	3Z82008
Measurement range <sup>(1)</sup>	mm	0.6	1.8	1.8	4	8	18	35	70	125	180
Standoff <sup>(2)</sup>	mm	9.5	14	18	43.5	44	70	95	145	200	250
Accuracy <sup>(3)</sup>	µm	2	3	3	4	6	10	15	35	70	100
Linearity <sup>(4)</sup>	±%	0.33	0.17	0.17	0.1	0.08	0.06	0.05	0.05	0.06	0.06
Reproducibility (dynamic) <sup>(5)</sup>	µm	0.15	0.4	0.4	0.6	1	2	4	15	25	35
X laser spot size <sup>(7)</sup>	µm	20	27	27	34	37	47	63	85	105	126
Angular coverage <sup>(8)</sup>	°	150	150	150	150	170	170	170	170	170	170

## Smart Sensor Functionality

User Interface		Web based, doesn't require software installation
Supported platform		Windows\iOS\Android with Google Chrome Web Browser (version 55.x.x.x or higher)
Profile Triggers		External Trigger\Position\Direction\Time
Encoders		Configurable encoder input and pulse to position conversion
Analysis		Profile Analysis with Go\No Go result
Maximum profile size	Points	90,000
Supported Anchors		14
Supported Features		27
Maximum features in profile		8
Digital Output	TTL\VTTL	Multiple digital outputs over single wire with configurable pulse length
Maximum Job Storage		1000 jobs
Reports		Evaluation results, filtering by date and by job
Job management		Import\Export Jobs
Units		Metric\Imperial units, Degrees\Radians

## Sensor General Specifications

Measurement frequency	Hz	Up to 10,000
Dimensions (without lens)	mm	140 x 79 x 57
Weight	gr	700

## Interface

Communication		Ethernet 10/100 UDP with SDK, HTTP with Google Chrome
Software development kit		C, C++, C#, Labview

## Analog signal (optional)

Boundary ranging	V	±4.5± 0.004
Analog linearity (9)	%	±0.1

## Light source

Type		Red laser
Laser safety class		Class 2, IEC 60825-1:2007 complies with 21 CFR 1040.10 and 1040.11 Laser Notice No.50

## Electrical specification

Power supply voltage		12 VDC±10% 110-220 VAC 50/60Hz
----------------------	--	--------------------------------

## Synchronization

Trigger input	TTL\VTTL	5\3.3V
Encoders		Up to 2 differential quadrature encoders

## Environmental resistance

Operational temperature	°C	°C
Temperature dependency (10)	F.S./°C	0.03%
Permissible ambient light (11)	lx	Up to 15,000

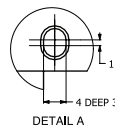
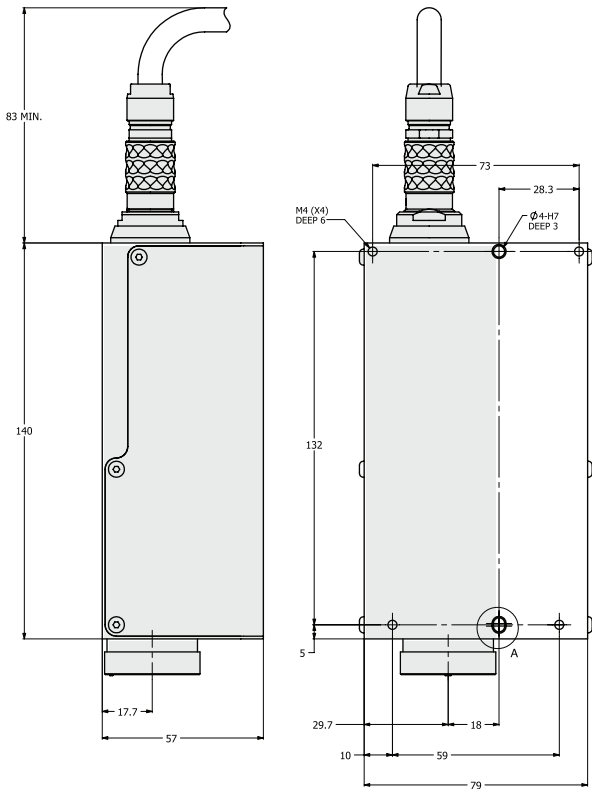

## Smart sensor GUI:



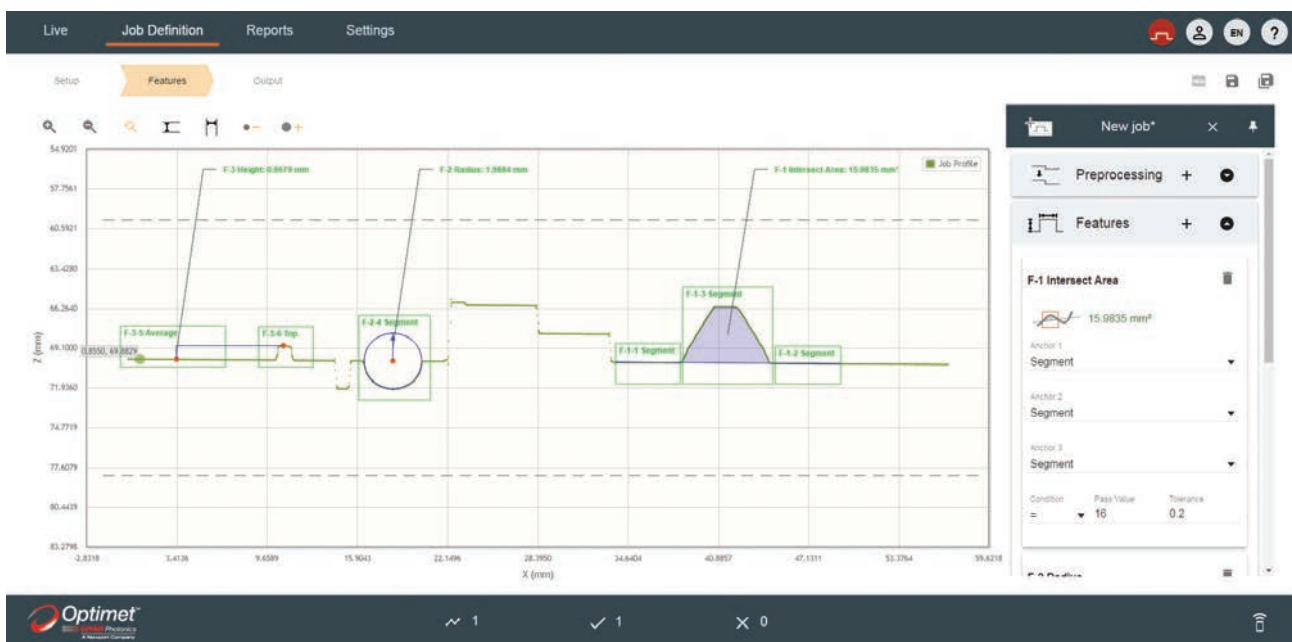



Live screen: up to 8 features on one profile.











## Anchors and Features

Anchors are calculated reference point of a feature used in order to evaluate measurement result.

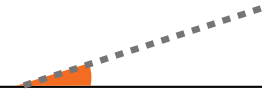
### Anchors examples

	Top
	Bottom
	Average
	Right Corner
	Rising edge
	Circle center

### Features examples

	Distance	Determines the Euclidean distance between two anchors
	Height	Difference along the Z axis between two anchors
	Width	Difference along the X axis between two anchors
	Angle X	Determines the angle between a fit line and the X axis
	Intersect Angle	Finds the angle subtended by two fitted lines
	Area	Measures the difference in cross-sectional area between live profile and the template.
	Radius	Finds the best-fitted circle and measures the circle radius
	Groove Width	Measures the width of a groove
	Groove Depth	Measures the depth of a groove as the maximum perpendicular distance from a line connecting the edge points of the groove

# ConoPoint-20

## Laser displacement sensor

The ConoPoint-20 is the latest version in Optimet's family of point sensors. It's a non-contact optical sensor for distance and 3D measurements based on the unique Conoscopic Holography technology. The ConoPoint-20 measures the distance to a single point at a rate of up to 20,000 points/second with up to sub-micron precision.



### Features:

- The ConoPoint-20 offers a variety of objective lenses allowing various accuracies, resolutions, standoffs and measurement ranges in the same sensor
- All data processing is performed in the sensor head
- The ConoPoint-20 supports external and internal trigger operation modes
- Communication to PC is accomplished via standard Ethernet
- Software integration is possible by using DLL without any additional drivers or setups
- Measurement rate up to 20,000 Hz
- Sub-micron precision with short focal length objectives
- Analog output (optional)
- Auto-exposure mode enabling measurement of high and low reflective surfaces in real time without changing laser power
- Measurement of complex geometries, steep grooves, and angles up to  $\pm 85^\circ$
- Integration capability with relay optics
- The sensor can act as a master synchronizer or as a slave synchronized by a system
- OPS (Optimet Position Synchronizer) capability which records encoders output and synchronizes the accurate position of up to three system axes together with the sensor's measurements

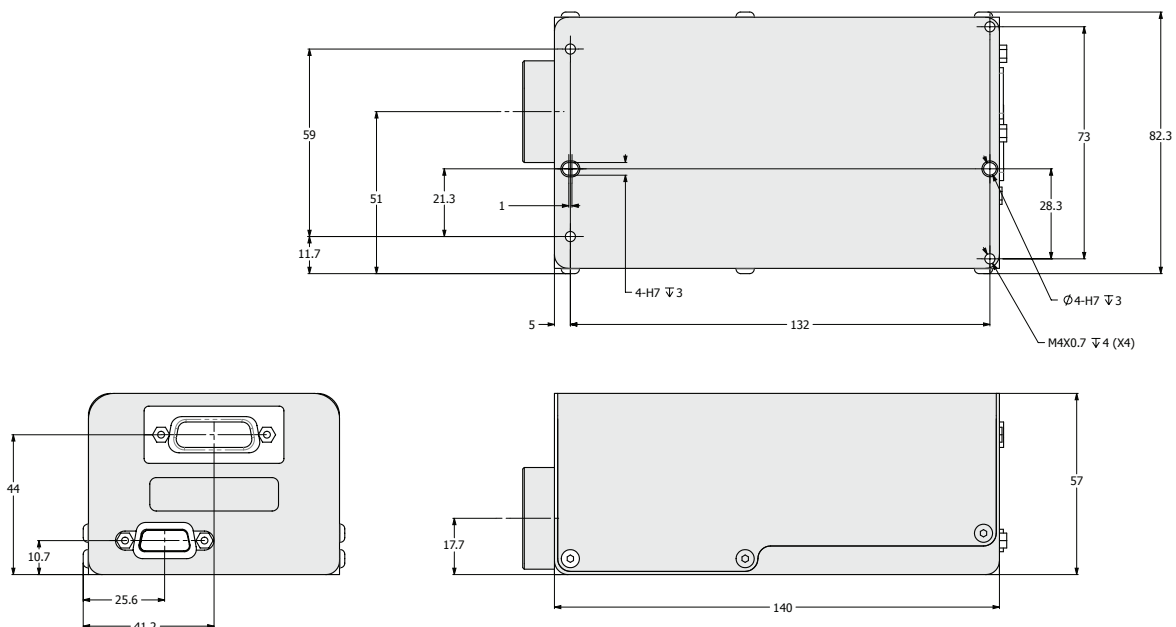

# Technical specification

## Standard lenses

Objective lens type		16	25	25G	40	50	75	100	150	200	250
P/N		3Z83016	3Z83025	3Z81030	3Z83040	3Z81050	3Z81075	3Z81100	3Z82006	3Z82007	3Z82008
Measurement range <sup>(1)</sup>	mm	0.6	1.8	1.8	4	8	18	35	70	125	180
Standoff <sup>(2)</sup>	mm	9.5	14	18	43.5	44	70	95	145	200	250
Accuracy <sup>(3)</sup>	µm	2	3	3	4	6	10	15	35	70	100
Linearity <sup>(4)</sup>	±%	0.33	0.17	0.17	0.1	0.08	0.06	0.05	0.05	0.06	0.06
Reproducibility (dynamic) <sup>(5)</sup>	µm	0.15	0.4	0.4	0.6	1	2	4	15	25	35
X laser spot size <sup>(7)</sup>	µm	20	27	27	34	37	47	63	85	105	126
Angular coverage <sup>(8)</sup>	°	150	150	150	150	170	170	170	170	170	170

## Sensor general specifications

Measurement frequency	Hz	Up to 20,000
Dimensions (without lens)	mm	140x79x57
Weight	gr	700

## Interface

Communication	Ethernet 10/100 UDP
Software development kit	C, C++, C#, Labview

## Analog signal (optional)

Boundary ranging	V	±4.5 ±0.004
Analog linearity <sup>(9)</sup>	%	±0.1

## Light source

Type	Red laser
Laser safety class	Class 3R, IEC60825-1:2014 complies with 21CFR and 1040.11 Laser Notice No.50

## Electrical specification

Power supply voltage	12 VDC±10% 65-265 VAC 50/60Hz
----------------------	-------------------------------

## Synchronization

Trigger input	TTL/LVTTL	5/3.3V
Strobe output	TTL	5V

## Environmental resistance

Operational temperature	°C	18 to 45
Temperature dependency <sup>(10)</sup>	F.S./°C	≤0.03%
Permissible ambient light <sup>(11)</sup>	lx	Up to 15,000

## \*Preliminary spec

## Measurement range

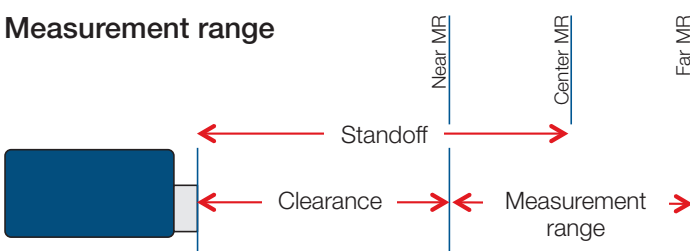

# ConoPoint-10

## Laser displacement sensor

The ConoPoint-10 is a sensor for high precision 2D profiles and 3D measurements, working at up to 10,000 Hz.

The ConoPoint-10 includes an auto-exposure feature enabling real time adjustment for changing surface reflectivity (black, white and absorbent).



### Features:

- Measurement of complex geometries with angular coverage up to  $\pm 85^\circ$
- Collinear technology for measuring blind holes
- Automatically compensates for material variations using auto-exposure
- Interchangeable objective lenses from 16 to 250 mm
- Measures at 10,000 points/second, no averaging needed

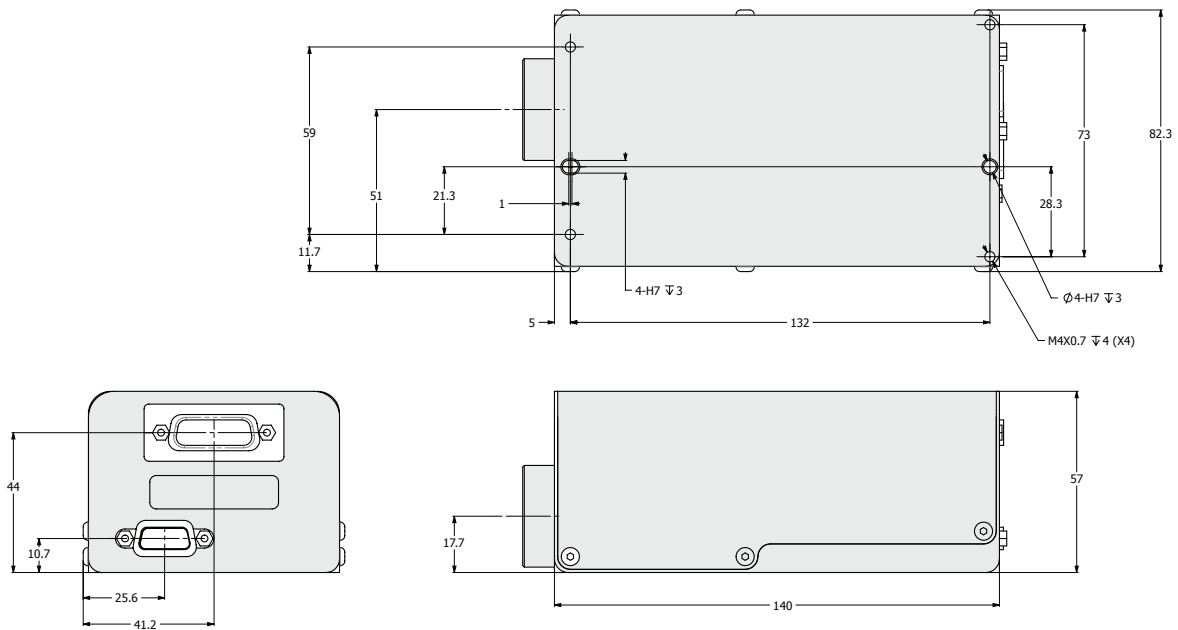

# Technical specification

## Standard lenses

Objective lens type		16	25	25G	40	50	75	100	150	200	250
P/N		3Z83016	3Z83025	3Z81030	3Z83040	3Z81050	3Z81075	3Z81100	3Z82006	3Z82007	3Z82008
Measurement range <sup>(1)</sup>	mm	0.6	1.8	1.8	4	8	18	35	70	125	180
Standoff <sup>(2)</sup>	mm	9.5	14	18	43.5	44	70	95	145	200	250
Accuracy <sup>(3)</sup>	µm	2	3	3	4	6	10	15	35	70	100
Linearity <sup>(4)</sup>	±%	0.33	0.17	0.17	0.1	0.08	0.06	0.05	0.05	0.06	0.06
Reproducibility (dynamic) <sup>(5)</sup>	µm	0.15	0.4	0.4	0.6	1	2	4	15	25	35
X laser spot size <sup>(7)</sup>	µm	20	27	27	34	37	47	63	85	105	126
Angular coverage <sup>(8)</sup>	°	150	150	150	150	170	170	170	170	170	170

## Special lenses

Objective lens type		High power sensitivity				Extended		
		100S	150S	200S	250S	50E	75E	125E
P/N		3Z84100	3Z84150	3Z84200	3Z84250	3Z83050E	3Z83075E	3Z83125E
Measurement range <sup>(1)</sup>	mm	35	70	125	180	8	18	45
Standoff <sup>(2)</sup>	mm	92	142	197	247	85	145	240
Accuracy <sup>(3)</sup>	µm	15	35	70	100	6	10	24
Linearity <sup>(4)</sup>	±%	0.04	0.05	0.06	0.06	0.08	0.06	0.064
Reproducibility (dynamic) <sup>(5)</sup>	±µm	4	15	25	35	1	2	6.4
X laser spot size <sup>(7)</sup>	µm	63	85	105	126	63	85	126
Angular coverage <sup>(8)</sup>	°	170	170	170	170	170	170	170

## Sensor general specifications

Measurement frequency	Hz	Up to 10,000
Dimensions (without lens)	mm	140x79x57
Weight	gr	700

## Interface

Communication	Ethernet 10/100 UDP
Software development kit	C, C++, C#, Labview

## Analog signal (optional)

Boundary ranging	V	±4.5 ± 0.004
Analog linearity <sup>(9)</sup>	%	±0.1

## Light source

Type	Red laser
Laser safety class	Class 2, IEC 60825-1:2007 complies with 21CFR 1040.10 and 1040.11 Laser Notice No.50

## Electrical specification

Power supply voltage	12 VDC±10% 65-265 VAC 50/60Hz
----------------------	-------------------------------

## Environmental resistance

Operational temperature	°C	18 to 45
Temperature dependency <sup>(10)</sup>	F.S./°C	≤0.03%
Permissible ambient light <sup>(11)</sup>	lx	Up to 15,000

## Synchronization

Trigger input	TTL/LVTTL	5/3.3V
Strobe output	TTL	5V

# ConoPoint-10HD

## Laser displacement sensor

The ConoPoint-10HD is one of Optimet's family of point sensors for high precision 2D profiles and 3D measurements, working at up to 10,000 Hz.

The ConoPoint-10HD includes an auto-exposure feature enabling real time adjustment for changing surface reflectivity (black, white, shiny and absorbent).



The ConoPoint-10HD is more suitable than the ConoPoint-10 in the following cases:

- When higher precision is needed. Note that while standoff is the same as ConoPoint-10, the higher precision comes at the expense of measurement range
- When measuring shiny metal surfaces
- When higher lateral resolution is needed

## Features:

- Sub-micron precision measurement
- Measurement of complex geometries with angular coverage up to  $\pm 75^\circ$
- Collinear technology for measuring blind holes
- Automatically compensates for material variations using auto-exposure
- Interchangeable objective lenses from 16 to 50 mm
- Measures at 10,000 points/second, no averaging needed

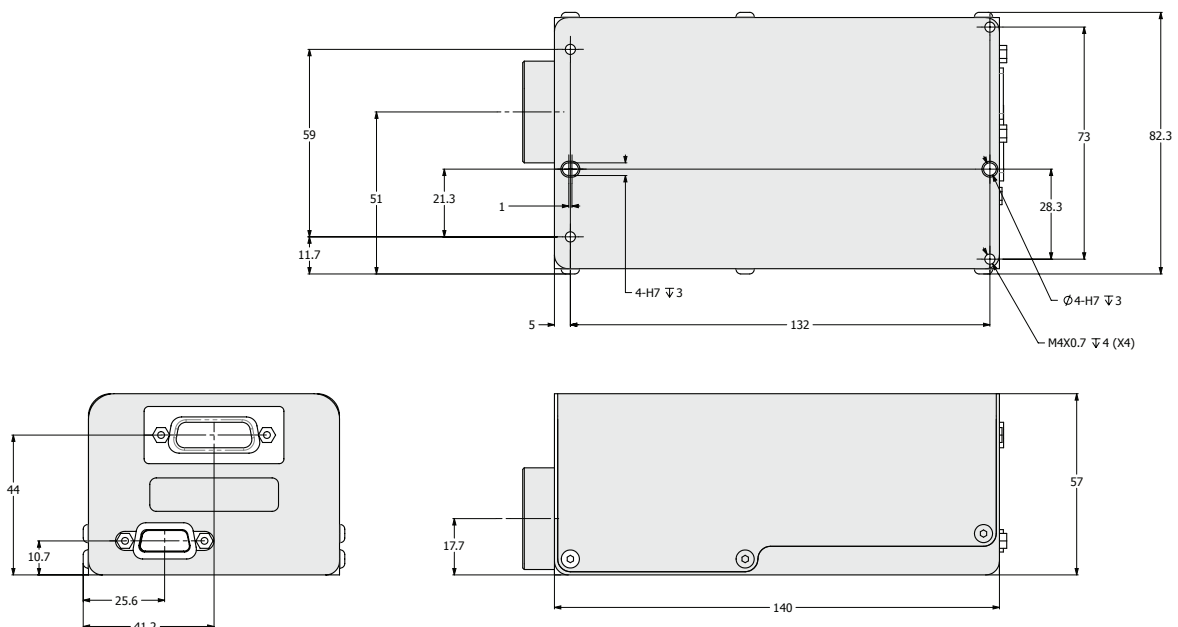



# Technical specification

## High definition lenses

Objective lens type		16H	25H	25GH	40H	50H
P/N		3Z84016	3Z81025	3Z81030	3Z83040	3Z81050T
Measurement range <sup>(1)</sup>	mm	0.2	0.6	0.6	1.4	2
Standoff <sup>(2)</sup>	mm	9.7	14.5	18.25	44.5	42
Accuracy <sup>(3)</sup>	μm	0.5	1	1	2	2.5
Linearity <sup>(4)</sup>	±%	0.25	0.17	0.17	0.14	0.13
Reproducibility (dynamic) <sup>(5)</sup>	μm	0.1	0.2	0.2	0.4	0.5
X laser spot size <sup>(7)</sup>	μm	7	12	12	10	19
Angular coverage <sup>(8)</sup>	°	150	150	150	150	150

## Sensor general specifications

Measurement frequency	Hz	Up to 10,000
Dimensions (without lens)	mm	140x79x57
Weight	gr	700

## Interface

Communication	Ethernet 10/100 UDP
Software development kit	C, C++, C#, Labview

## Analog signal (optional)

Boundary ranging	V	±4.5 ± 0.004
Analog linearity <sup>(9)</sup>	%	±0.1

## Light source

Type	Red laser
Laser safety class	Class 2, IEC 60825-1:2007 complies with 21CFR 1040.10 and 1040.11 Laser Notice No.50

## Electrical specification

Power supply voltage	12 VDC±10% 65-265 VAC 50/60Hz
----------------------	-------------------------------

## Synchronization

Trigger input	TTL/LVTTL	5/3.3V
Strobe output	TTL	5V

## Environmental resistance

Operational temperature	°C	18 to 45
Temperature dependency <sup>(10)</sup>	F.S./°C	≤0.03%
Permissible ambient light <sup>(11)</sup>	lx	Up to 15,000

## Measurement range

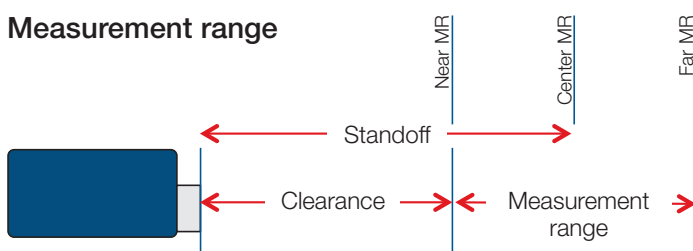

# ConoPoint-3

## Laser distance sensor

The ConoPoint-3 is a robust optical sensor for high precision measurements of distance, 2D profiles and 3D scanning. Based on conoscopic holography technology, the ConoPoint-3 is a collinear sensor with a wide range of object coverage using interchangeable objective lenses between 16-250 mm.

Thousands of ConoPoints are used in production in a large variety of industrial applications.



### Features:

- Measurement of complex geometries, with angle coverage up to  $\pm 85^\circ$
- Collinear technology for measuring blind holes
- In process inspection
- Interchangeable objective lenses from 16 to 250 mm

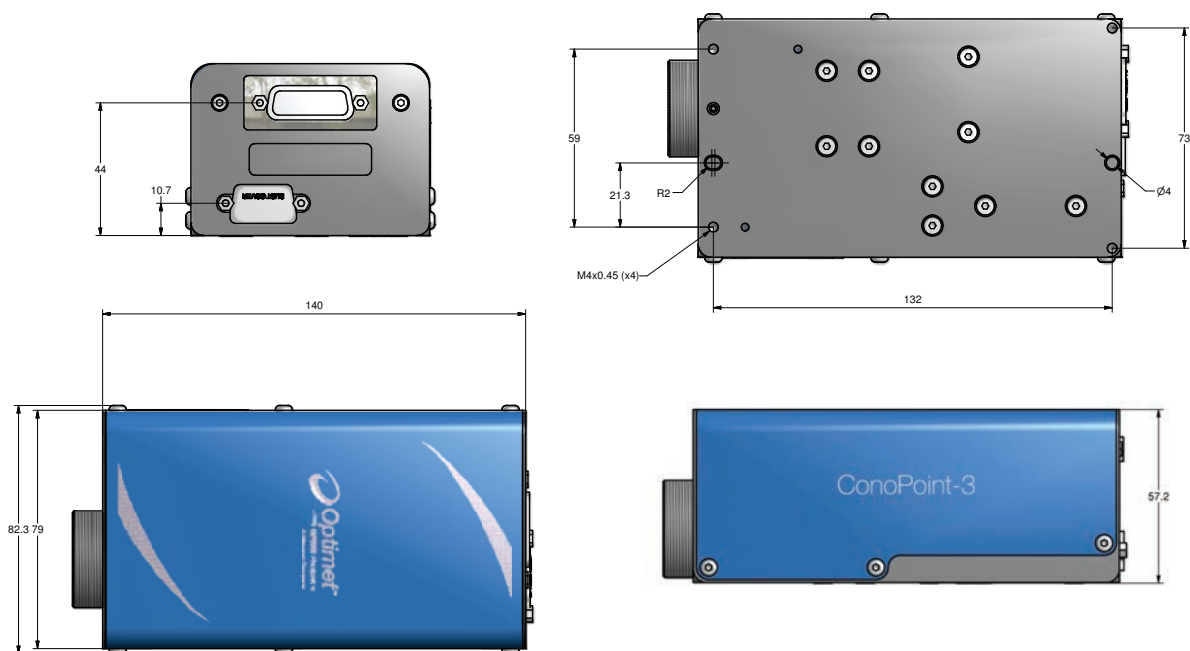

# Technical Specification

## Standard Lenses

Objective Lens type		16	25	25G	40	50	75	100	150	200	250
P/N		3Z83016	3Z83025	3Z81030	3Z83040	3Z81050	3Z81075	3Z81100	3Z82006	3Z82007	3Z82008
Measurement Range	mm	0.6	1.8	1.8	4	8	18	35	70	125	180
Standoff	mm	9.5	14	18	43.5	44	70	95	145	200	250
Linearity	±%	0.33	0.17	0.17	0.1	0.08	0.06	0.04	0.05	0.06	0.06
Repeatability	µm	0.02	0.06	0.06	0.04	0.10	0.30	0.50	2.50	3	6
X laser Spot Ssize	µm	20	27	27	34	37	47	63	85	105	126
Angular Coverage	°	150	150	150	150	170	170	170	170	170	170

## Special Lenses

Objective Lens type		Extended		
P/N		50E	75E	125E
Measurement Range	mm	8	18	45
Standoff	mm	85	145	240
Linearity	±%	0.08	0.06	0.064
Repeatability	µm	0.1	0.1	0.05
X laser Sspot Size	µm	63	85	126
Angular Coverage	°	170	170	170

## Sensor General Specifications

Measurement Frequency	Hz	Up to 3,000
Dimensions (without lens)	mm	140x79x57
Weight	gr	700

## Interface

Communication	Ethernet 10/100 /1000 UDP
Software Development Kit	C, C++, C#, Labview

## Analog signal (Optional)

Boundary Ranging	±4.5 V ± 0.004 V
Analog Linearity	±0.1%

## Light source

Type	Red Laser
Laser Safety Class	Class 2, IEC 60825-1:2007 complies with 31CFR 1040.10 and 1040.11 class II - FDA

## Electrical specification

Power Supply Voltage	12 VDC±10% 65-265 VAC 50/60Hz
----------------------	-------------------------------

## Synchronization

Trigger Input	TTL/LVTTL	5/3.3V
Strobe Output	TTL	5V

## Environmental resistance

Operational Temperature	°C	18 to 45
Temperature Stability	F.S./°C	±0.1%
Permissible Ambient Light	lx	Up to 15,000

# ConoPoint-3R

## Laser displacement sensor

The ConoPoint-3R is one of Optimet's family of point sensors for non-contact high precision measurements of distance, 2D profile and 3D surface scanning. The ConoPoint-3R is used for scanning transparent materials such as glass or liquids, and specular materials like mirrors and wafers.

The ConoPoint-3R can also measure glass thickness and transparent coating layers by simultaneous reading of both top and bottom surface reflections.

The ConoPoint-3R reaches sub-micron depth resolution using interchangeable objective lenses with lateral resolution of below  $1\mu\text{m}$ .



### Features:

- High precision and repeatability
- Small spot size less than  $5\mu\text{m}$
- Collinear in-process inspection point sensor
- Flexible measurement ranges and standoffs due to interchangeable objective lenses
- True measurement rate of up to 3,000 point/second, with no averaging needed
- Optional synchronization with up to 3 axis system
- Robust product for industrial environment and production floor
- Detailed API manual and SDK with hardware emulator

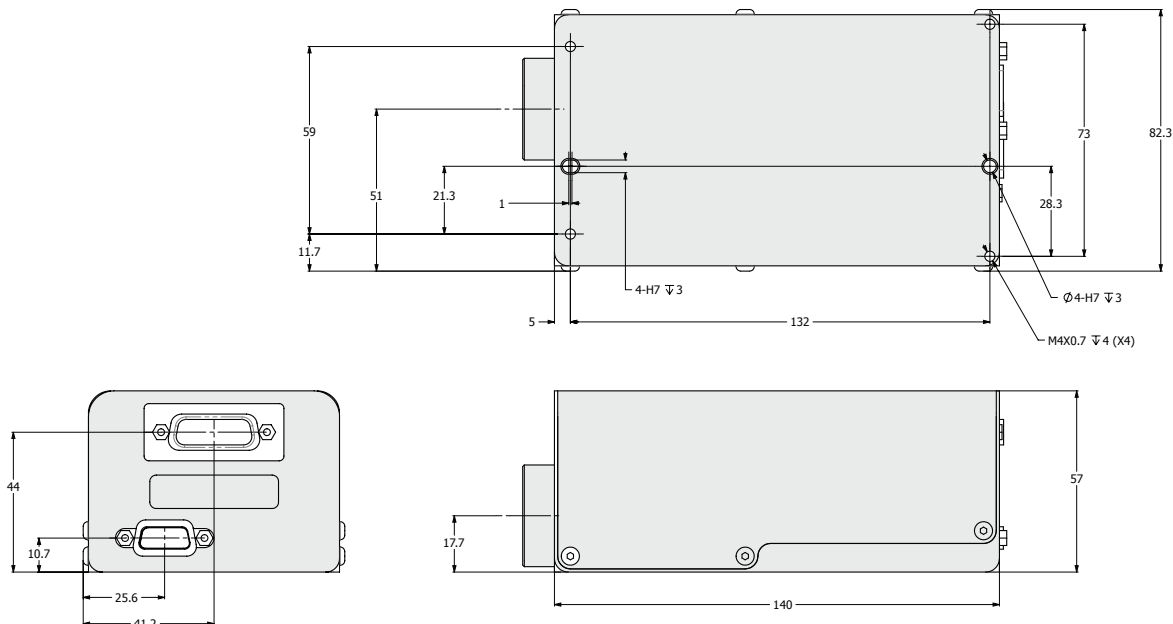

# Technical specification

## Standard lenses

Objective lens type		25N	50N	75N
P/N		3Z79030	3Z79050	3Z79075
Measurement range <sup>(1)</sup>	mm	1	5	9
Standoff <sup>(2)</sup>	mm	16	40	65
Accuracy <sup>(3)</sup>	µm	1	2.5	4.5
Physical thickness range	mm	0.3-1	1.5-5	2.7-9
Linearity <sup>(4)</sup>	±%	0.1	0.05	0.05
X laser spot size <sup>(7)</sup>	µm	5	16	25
Angular coverage <sup>(8)</sup>	°	5	3	1.5

## Sensor general specifications

Measurement frequency	Hz	Up to 3,000
Dimensions (without lens)	mm	140 x 79 x 57
Weight	gr	700

## Interface

Communication	Ethernet 10/100 UDP
Software development kit	C, C++, C#, Labview

## Analog signal (optional)

Boundary ranging	V	±4.5 ± 0.004
Analog linearity <sup>(9)</sup>	%	±0.1

## Light source

Type	Red laser
Laser safety class	Class 2, IEC 60825-1:2007 complies with 21CFR 1040.10 and 1040.11 Laser Notice No.50

## Electrical specification

Power supply voltage	12 VDC±10% 65-265 VAC 50/60Hz
----------------------	-------------------------------

## Synchronization

Trigger input	TTL/LVTTL	5/3.3V
Strobe output	TTL	5V

## Environmental resistance

Operational temperature	°C	18 to 45
Temperature dependency <sup>(10)</sup>	F.S./°C	≤0.03%
Permissible ambient light <sup>(11)</sup>	lx	Up to 15,000

## Measurement range

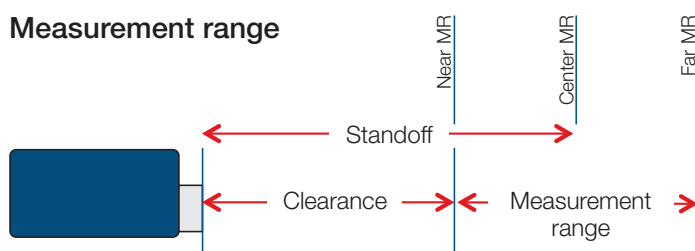

# Mini ConoPoint-9R

## Laser displacement sensor

The Mini ConoPoint-9R is one of Optimet's new generation of point sensors for reflective and specular surfaces. Endowed with an especially small footprint and low weight, it's the optimal sensor for True profile measurement and 3D scanning of specular and transparent materials with up to 9,000 Hz. It's perfect for in-process QC inspection and glass scratch analysis.

The Mini ConoPoint-9R can measure glass thickness and transparent coating layers by simultaneous reading of both top and bottom surface reflections.

The control unit is separated from the sensor which enables placing the small sensor at the most convenient location and on light weight CMM machinery



### Features:

- Low weight and small footprint
- High precision and repeatability below 1µm
- True measurement rate of up to 9,000 point/second, with no averaging needed
- Built-in quality parameters allow efficient filtering
- Small spot size less than 3µm
- Objective 25mm lens
- Easy setup, user friendly software controls sensors parameters and range indicators

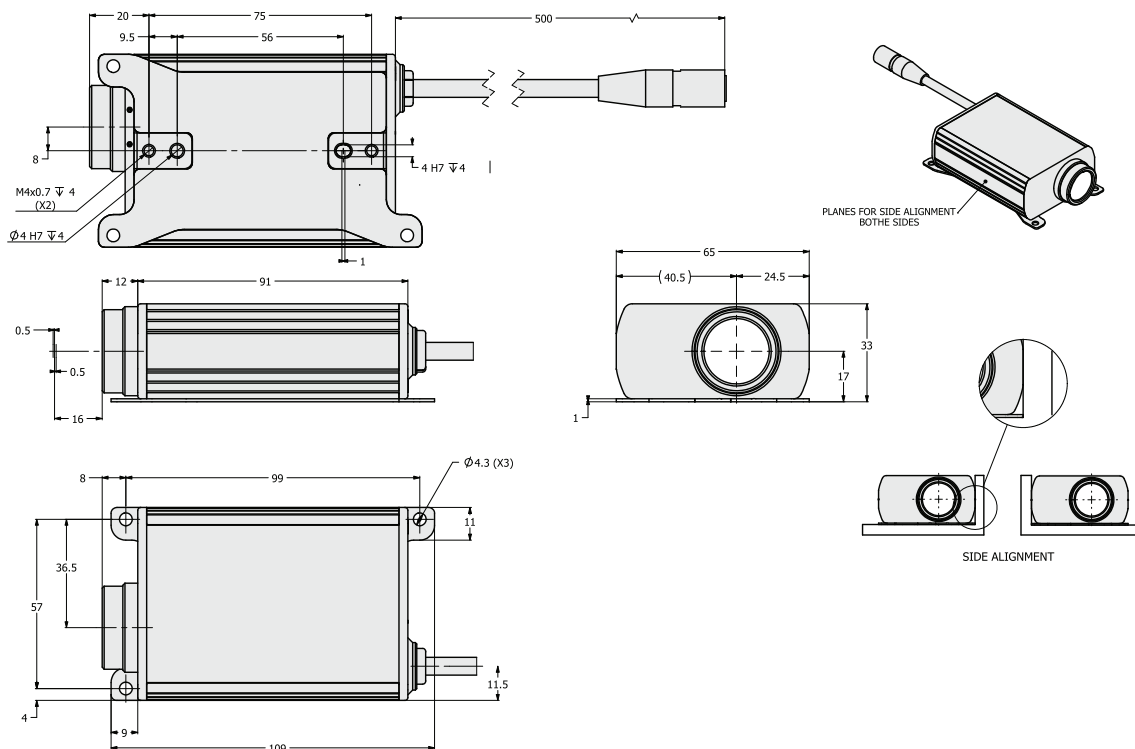

## Technical specification

Objective lens type		25
P/N		3Z79025
Measurement range <sup>(1)</sup>	mm	1
Standoff <sup>(2)</sup>	mm	16
Accuracy <sup>(3)</sup>	µm	0.6
Linearity <sup>(4)</sup>	±%	0.06
X laser spot size <sup>(7)</sup>	µm	3
Angular coverage <sup>(8)</sup>	°	6

### Sensor general specifications

Measurement frequency	Hz	9,000
Dimensions (L x W x H)	mm	91 x 65 x 33
Weight	gr	390
Cable length (sensor to controller)	m	Pigtailed 0.5m, optional 5/20m
Indicators	Green LED – On when sensor's power is on	
Conformity	Vibration (IEC 600068-2-6), Shock(IEC 600068-2-7)	

### Light source

Type	Red laser	
Laser safety class	Class 2, IEC 60825-1:2007 complies with 21CFR 1040.10 and 1040.11 Laser Notice No.50	

### Environmental resistance

Operational temperature	°C	18 to 35
Temperature dependency <sup>(10)</sup>	F.S./°C	≤0.03%
Permissible ambient light <sup>(11)</sup>	lx	Up to 15,000

### Control unit general specifications

Dimensions (L x W x H)	mm	105 x 167 x 54
Weight	gr	630
Control signal	ROG – output, External trigger – input, Analog output (optional) ±4.5 V, OPS (Position Synchronization), +5V output (100mA)	
Operating voltage	V	24 ±10% (0.5A)
Indicators	Connect: Green LED – On when sensor head connected; Power : Green LED – On when power is on	
Communication	Ethernet 10/100 UDP	
Software development kit	C, C++, C#, Labview	

# ConoLine-100

## Non-contact laser line displacement sensor

The ConoLine-100 is a non-contact optical line sensor for distance and 3D measurements based on the unique Conoscopic Holography technology.

The ConoLine-100 contains the new ConoPoint-20 sensor which has a measuring rate of up to 20,000 points per second, and a rotating mirror generating up to 100 lines per second.

The ConoLine-100 offers an adjustable line length of up to 18mm and down to micron precision. Controlling the mirror's position enables an angular coverage of  $\pm 110^\circ$  allowing a clear view of undercuts, steep grooves and side walls.



### Features:

- Adjustable line length allowing various lateral resolutions and scanning speed with up to 100 lines/second
- Adjustable line angle allowing scans of undercuts, steep grooves and side walls
- Angular coverage of  $\pm 110^\circ$
- Measuring rate of up to 20,000 Hz
- Supports external and internal trigger operation mode
- Communication to PC is accomplished via standard Ethernet
- Easy software integration with DLL without additional drivers or setup
- Auto-exposure mode enabling measurement of high and low reflective surfaces in real time without changing laser power

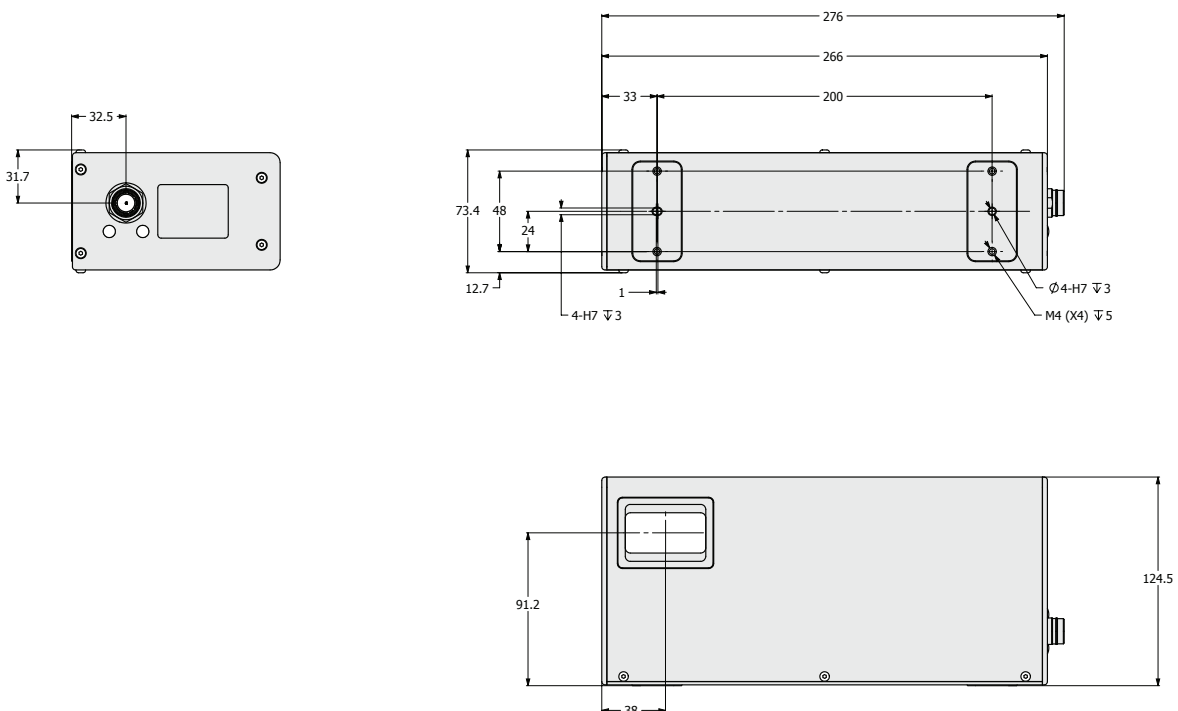



# Technical specification\*

## Vertical axis Z

Measurement range <sup>(1)</sup>	mm	30
Standoff <sup>(2)</sup>	mm	50
Accuracy <sup>(3)</sup>	µm	20
Linearity <sup>(4)</sup>	±%	0.05
Reproducibility (dynamic) <sup>(5)</sup>	µm	6
Angular coverage X <sup>(8)</sup>	°	170

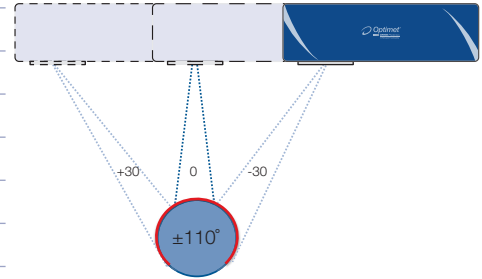

Angular coverage of ±110°

## Line specifications

Lines / sec		100
Line span	°	10
Line length @ near range	mm	13
Line length @ center range	mm	15.5
Line length @ far range	mm	18
Line resolution @ mid range	mm	0.09
Line width (X direction) @ center range	µm	47
Adjustable line angle	°	-30, -25, -20, -15, -10, -5, 0, +5, +10, +15, +20, +25, +30
Angular coverage (X)	°	220

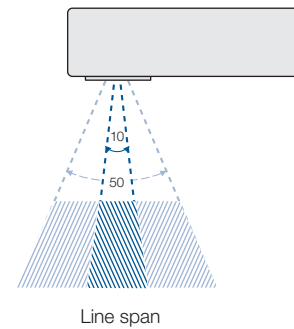

Line span

## Sensor general specifications

Measurement frequency	Hz	Up to 20,000
Dimensions	mm	260X110X65
Weight	gr	2100

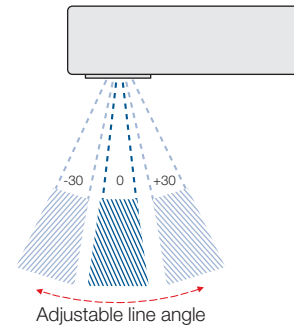

Adjustable line angle

## Interface

Communication		Ethernet 10/100 UDP
Software SDK		C, C++, C#, Labview

## Light source

Type		Red laser
Laser safety class		Class 3R, IEC60825-1:2014 complies with 21CFR and 1040.11 Laser Notice No.50

## Electrical specification

Power supply voltage		24 VDC±10% 65-265 VAC 50/60Hz
----------------------	--	-------------------------------

## Synchronization

Trigger input	TTL/VTTL	5/3.3V
Strobe output	TTL	5V

## Environmental resistance

Operational temperature	°C	18 to 45
Temperature dependency <sup>(10)</sup>	F.S./°C	≤0.03%
Permissible ambient light <sup>(11)</sup>	lx	Up to 15,000

## Hardware enable measurement

Hardware mode		High,low,Pulse
Hardware digital trigger		5-24V

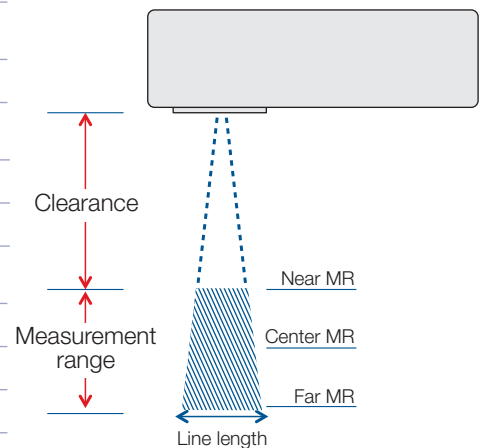

# ConoPoint with periscope

## Laser displacement sensor for hole measurement

The periscope is a unique accessory developed by Optimet which overcomes some basic limitations when measuring diameters, steep angles and inner structures of holes and pipes. The periscope is integrated with a regular 75mm lens and enables measuring perpendicularly to the sensor's standard direction. It has all advantages and accuracies of the ConoPoint with the add-ons of measuring areas impossible to reach otherwise.



### Features:

- Inspection at 90° related to a standard sensor direction
- Available with 75mm lens, other lenses can be customized upon request
- The periscope can be rotated 180° by user to reach desirable measuring direction
- All of the advantages and features as a regular ConoPoint sensor
- Angular coverage of 150°
- Telescopic joint design prevents tip damage in axial direction

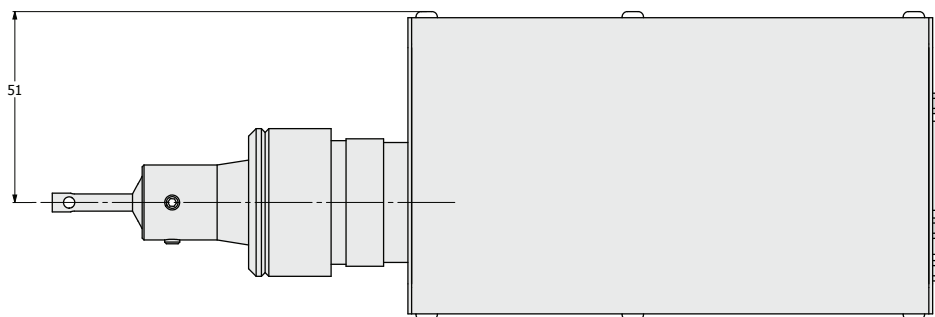
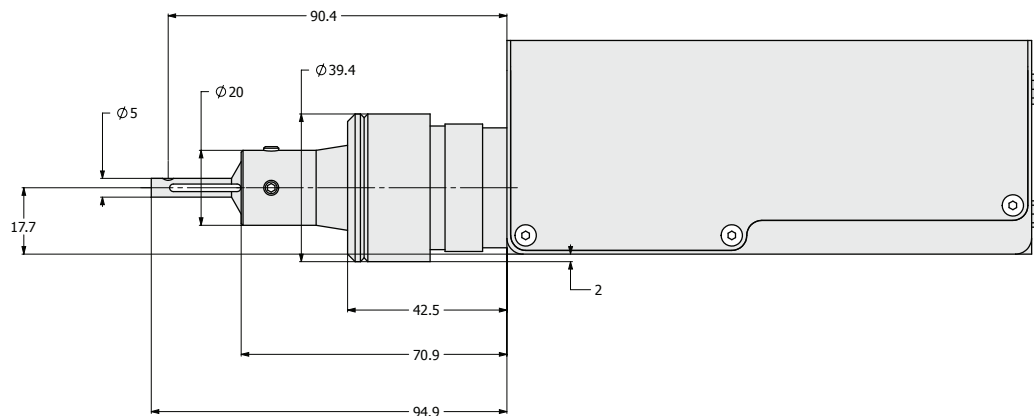

## Technical specification

Accessory type		Periscope for 75mm lens
P/N		3Z80510
Measurement range <sup>(1)</sup>	mm	9.5
Standoff <sup>(2)</sup>	mm	0.5
Accuracy <sup>(3)</sup>	µm	10
Linearity <sup>(4)</sup>	±%	0.15
Reproducibility (dynamic) <sup>(5)</sup>	µm	3
X laser spot size <sup>(7)</sup>	µm	47
Angular coverage <sup>(8)</sup>	°	150

### General specifications

Weight periscope	gr	120
------------------	----	-----

### Maximum depth range

Maximum penetration	mm	15
Minimum hole diameter	mm	6

---

## Parameter explanations

- (1) **Measurement Range:** Effective range of the sensor
- (2) **Standoff:** Distance from the tip of the objective lens to the center of the measurement range
- (3) **Accuracy:** Difference between two flat surfaces measured as compared to nominal value
- (4) **Linearity:** Maximum deviation between measurement and its nominal distance over the measurement range
- (5) **Reproducibility (dynamic):** Average of STD between two flat surfaces measured 50 times
- (6) **Repeatability (static):** Standard Deviation of 10000 static measurements of a flat surface
- (7) **X laser spot size:** Measured full width at half maximum (FWHM) at standoff position
- (8) **Angular coverage:** Tested on a flat reference plane of half of the defined angle
- (9) **Analog Linearity:** Maximum deviation between output voltage and its nominal distance over the measurement range
- (10) **Temperature dependency:** relative (differential) measurements at a range of 18-28°C. Distance value decreases with increased temperature
- (11) **Permissible ambient light:** tested using an incandescent light source near sensor objective surface

# Software

Optimet offers different software platforms to ease sensor integration.

The software development kit provided is compatible with Windows® 7, Windows® 8.1 and Windows® 10 operating systems. The SDK is compiled as 32/64 bit. The SDK has been successfully integrated into systems written in the following development environments

- C, C++, C#
- LabView 8.6 and higher

We offer the Smart probe tester GUI for initialization and sensor set-up:

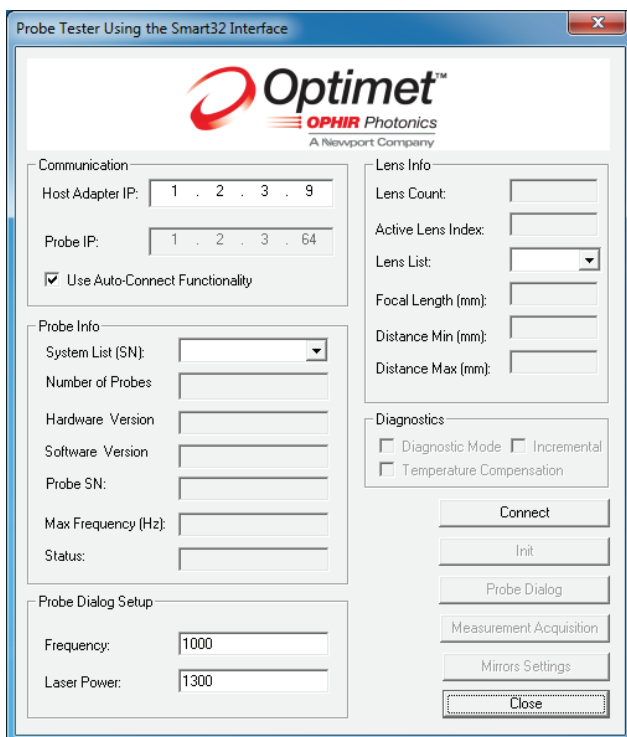

User can adjust laser power and CCD frequency. A graphic presentation of the signal is shown.



In this particular example one can see the **LabView** probe tester's main screen:

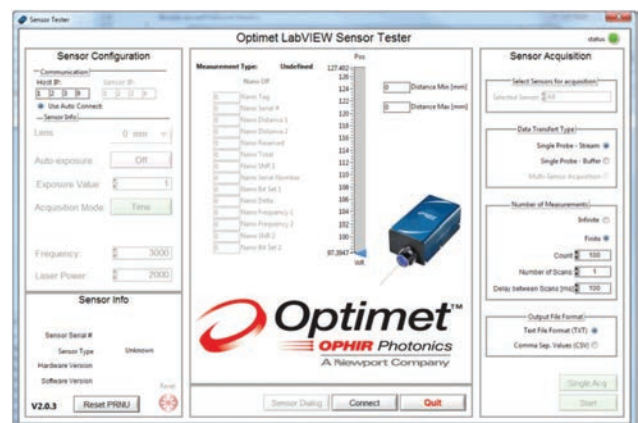

# Toolkit

The software toolkit includes a complete package of applications to configure and maintain the ConoPoint and ConoLine-100 sensors.

The following tools are included:

- **Lens Editor** - Application for adding and removing sensor objective lenses
- **Sensor Analyzer** – Application to view live output from the ConoLine-100 sensor
- **Sensor Configurator** – Application helps to configure sensor for easy integration with a PLC
- **Job Converter** - Application that allows converting scan data from ConoLine-100 to Optimet's job file

## Sensor configurator

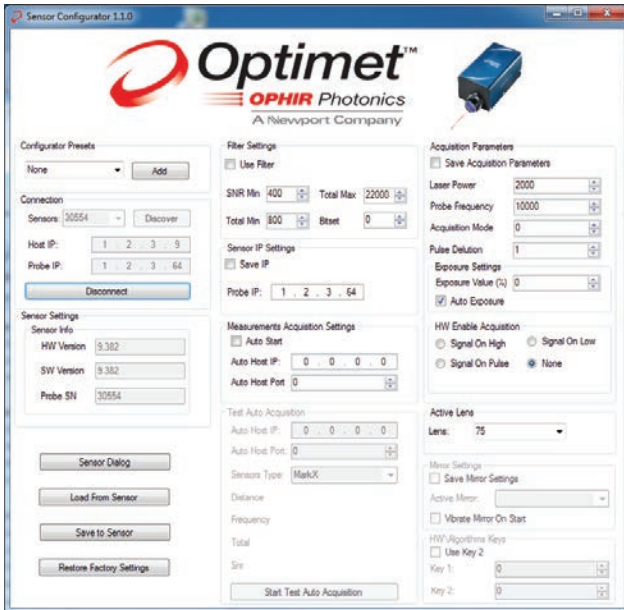

## Sensor analyzer



## Job converter

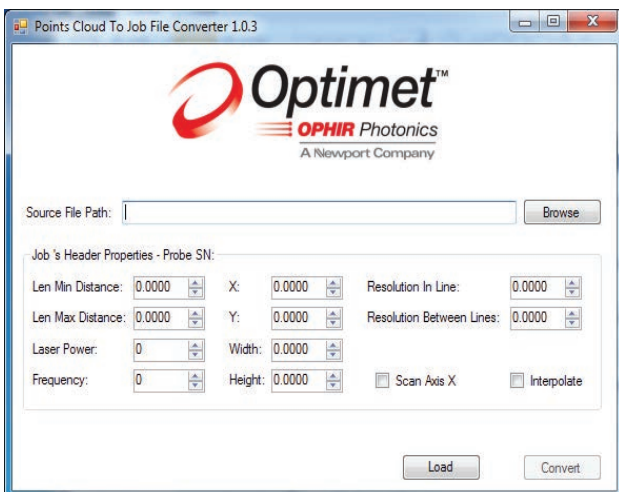

## Lens editor

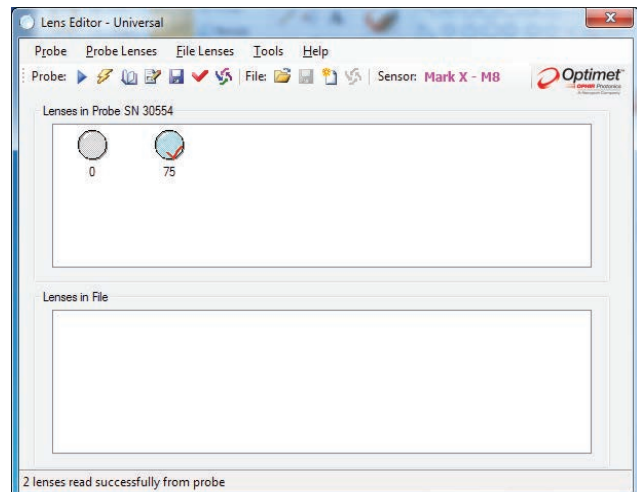

# Analysis software

The **Viewer software** is a user friendly, built-in profile analysis software provided with Optimet's products. The Viewer allows digital visualization of the scan and enables performance of metrological analysis. The data collected can be exported to other software programs for further analysis or CNC manufacturing.

## The Viewer software provides:

- **Data of slopes and angles of line segments**
- **Data of distance between segments** - the Viewer provides measurement data of the distance between the different sections of a profile, including vertical, horizontal, and absolute distance
- **Data of circular radius** - the Viewer defines and measures the circular radius of a scanned area.
- **Roughness analysis** - the Viewer can characterize surface roughness.
- **Finds a sphere center** - the Viewer finds the x-y-z location of a sphere center.
- **Filtering** - the Viewer increases accuracy by smoothing out or eliminating bad points in a profile scan.
- **Compares measurement profiles** - the Viewer can compare two profiles.
- **Circle fitting and analysis** - the Viewer provides data on the radial distance between any point in a profile and a circular segment in a profile.
- **Linearity and circularity analysis** - the Viewer provides information on the linearity or circularity of a given profile.
- **Effective radius** - the Viewer calculates the effective radius based on an area bound by a profile and two tangent lines.
- **Automation and macros** - the Viewer allows for automated repetitive profile analysis procedures in macro.

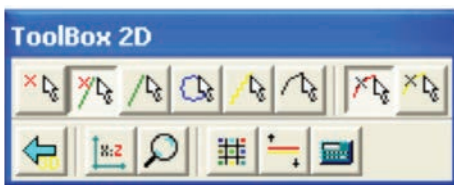

## Coin analysis

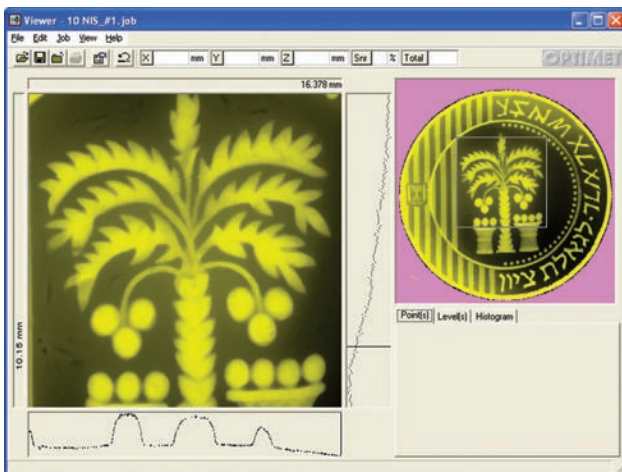

## Point to point delta measurement:

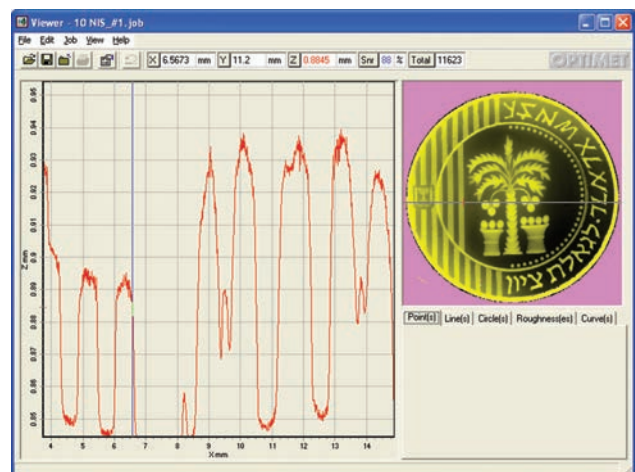

# TrueMap (optional)

## Surface topography visualization and analysis software

TrueMap is used to visualize the measurements results of Optimet's sensors and for in-depth analysis of acquired data. TrueMap offers diverse analysis tools including filters, fitting, form removal, and many others as well as visualization options such as dynamic scales and profile sections all in a live 3D graphic environment.

Optimet's engineers, together with TrueGage developers, have optimized TrueMap for Optimet's customers providing a unique and complete analysis package.

TrueMap is available and supported by TrueGage. To see TrueMap in action download the 14 days trial version <http://www.truegage.com/downloads/>

### 3D coin

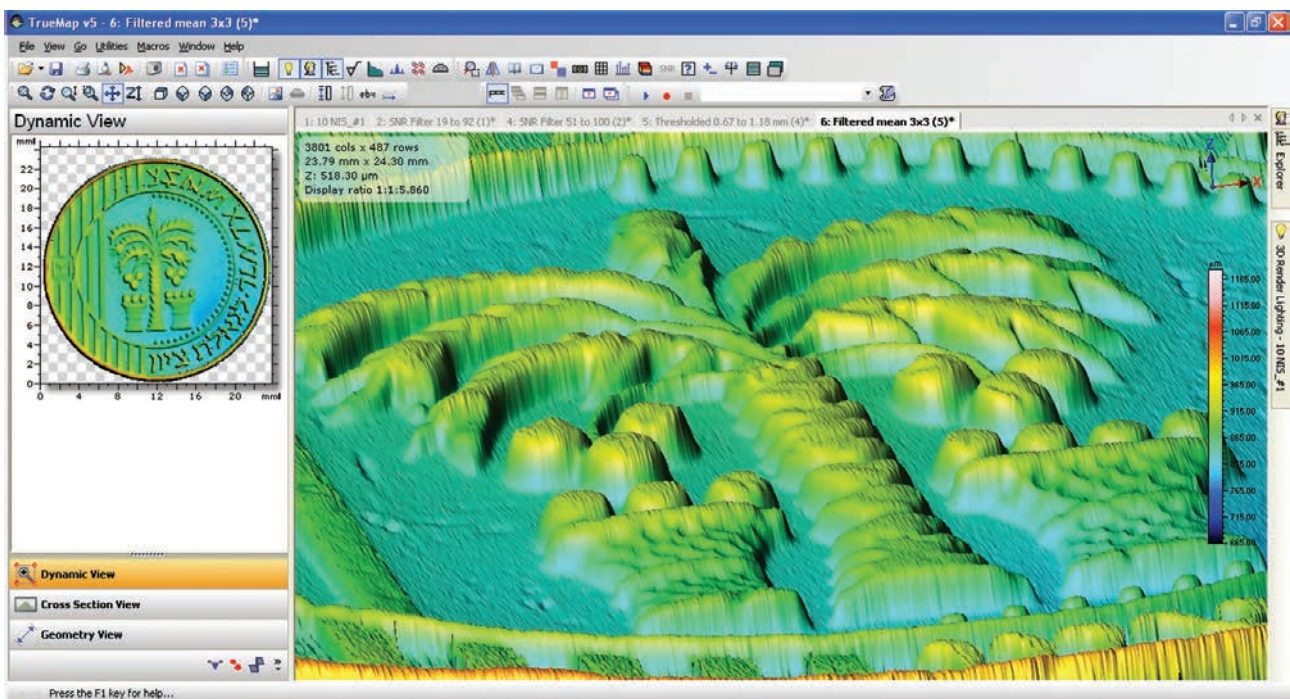

### Cellphone back panel

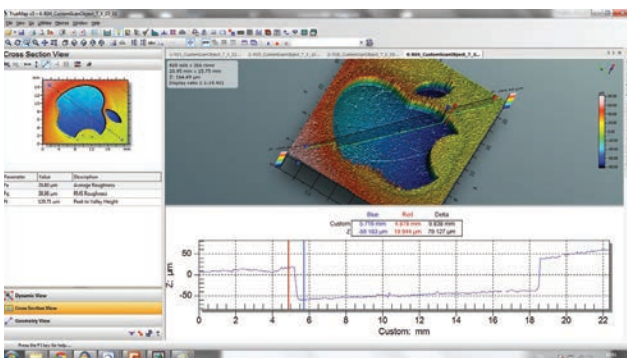

### Cellphone inner panel

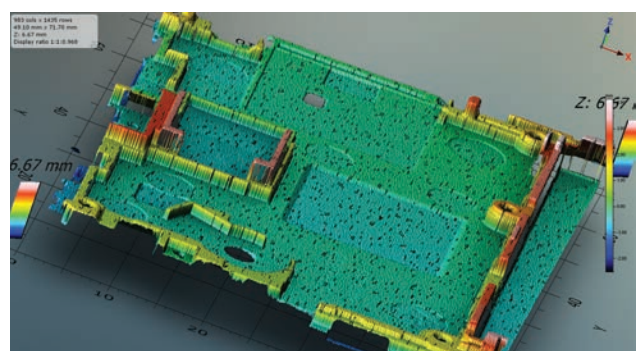

To obtain a better profile analysis **TrueMap** data can be used in **TrueSurf**.

Altogether Optimet offers a variety of software and analysis capabilities which complete the measurement procedure and offer the customer state-of-the-art data presentation.



# Beyond any measure

Endless possibilities of  
high precision industrial  
scanning and beyond

## Corporate sites

### **Optical Metrology Ltd.**

10 Hartom St.  
Jerusalem 9145001  
Israel

Tel: +972 2 5482900  
Fax: +972 2 5865387  
Email: [marketing@optimet.com](mailto:marketing@optimet.com)

[www.optimet.com](http://www.optimet.com)

### **Optimet, Unit of Newport Corp.**

1616 Osgood St.  
North Andover, MA 01845  
USA

Toll-Free: +1 877 446 0814  
Tel: +1 978 657 6303  
Fax: +1 978 657 6056  
Email: [sales@optimet.com](mailto:sales@optimet.com)  
[www.optimet.com](http://www.optimet.com)

### **Ophir Japan Ltd**

Towa 1 st Building 1F, 4-384  
Sakuragi, Omiya, Saitama city, Saitama  
Japan 330-0854

Tel: +81 48 6464150  
Fax: +81 48 6464155  
Email: [optimet@ophirjapan.co.jp.com](mailto:optimet@ophirjapan.co.jp.com)

[www.ophiropt.com/jp](http://www.ophiropt.com/jp)



# Distributors

Country	Company	Website	Email	Tel
China	Beijing Microview Science and Technology Co., Ltd	www.microview.com.cn	sunqi@microview.com.cn	+86 10 82600088/6821
China	Scan Direct Ltd	www.scan-direct.com.	angel@scan-direct.com.cn	86 21 51093099
China	Ningbo FLD-TECH Co., Ltd.	www.fld-tech.com	info@fld-tech.com	86 574 86829818
China	Shanghai DayK M&E Co.,Ltd	www.dayk.com.cn	jianping.zheng@dayk.com.cn	86 21 51966384
France	Optoprim France	www.optoprim.com	alanglois@optoprim.com	+33 01 41 90 61 80
France	Visionic	www.visionic.fr	xsavin@visionic.fr	33 02 358 180 00
Germany	Optoprim Germany	www.optoprim.de	cschroeter@optoprim.de	+49 (0)89 80076252
Germany	Soliton Laser-und Messtechnik GmbH	www.soliton-gmbh.de	T.Beckmann@soliton-gmbh.de	49 8105 7792 0
Greece	ACTA	www.acta.com.gr	ageo@acta.com.gr	+30 210 600 3302
India	ASA Technologies	www.asatech.in	info@asatech.in	+91 022 410 091 65
Italy	Optoprim S.R.L	www.optoprim.it	zagarella@optoprim.it	39 39 834977
Japan	Optoware	www.optoware.co.jp	kikuchi@optoware.co.jp	81 2 8440 1240
Korea	Dissem	www.dissem.co.kr	redfield@dissem.co.kr	82 31 383 3611
Poland	LSI – Laser systems Integrators	www.integrators.pl	pawel@integrators.pl	535 688 622
Russia	Crystal Techno	www.elektrosteklo.ru	okhrimenko@elektrosteklo.ru	+7 (495) 234-5951
Singapore	Inno-V Global	www.innov-global.com	sales@innov-global.com	+65 6296 1217
Spain	DSI PLUS	www.dsiplus.es	ialvarez@dsiplus.es	+34 984 10 60 48
Sweden	StemmerImaging AB	www.stemmer-imaging.se	H.Lindblom@stemmer-imaging.se	46 8 555 110 28
Taiwan	UNICE EO Services Inc	www.unice.com.tw	jimmy.chang@unice.com.tw	886 3 462 6569
Vietnam	SENSORS VIETNAM CO., LTD	www.sensors.vn	sales@sensors.vn	+34 984 10 60 48



ISO 9001:2008



[www.optimet.com](http://www.optimet.com)